

High Performance Butterfly Valves Index

Features & Benefits	HP-1
HP Series Lug with Lever 2 1/2" - 8"	HP-2
HP Series Lug with Gear 2 1/2" 8"	HP-3
HP Series Lug with Gear 10" - 24"	HP-4
HP Series Wafer with Lever 2 1/2" - 8"	HP-5
HP Series Wafer with Gear 2 1/2" - 8"	HP-6
HP Series Wafer with Gear 10" - 18"	HP-7

04/16



HP Series: Milwaukee Valve Company High Performance Butterfly Valves

Features and Benefits

- Double offset geometry to provide superior sealing with minimal seat contact and wear.
- Machined, tapered seat provides multiple sealing edges.
- Single piece shaft and disc designed for maximum strength and Cv.
- Internally cast disc position stop to prevent disc over travel while maintaining optimum disc/seat contact.
- Stem is centered in the adjustable stem packing by oversized bearings eliminating stem leakage and fugitive emissions.
- Disc spacers to center disc in seat to eliminate seat distortion.
- Blow out proof stem prevents injury and product loss.
- Combination mechanical and pressure energized seat design for repeatable and reliable sealing performance and extended cycle life
- Sealing retaining ring designed for double dead end service (lug style) and allows easy removal for seat replacement.
- Stem/disc connection ensures minimal lost motion and high strength.

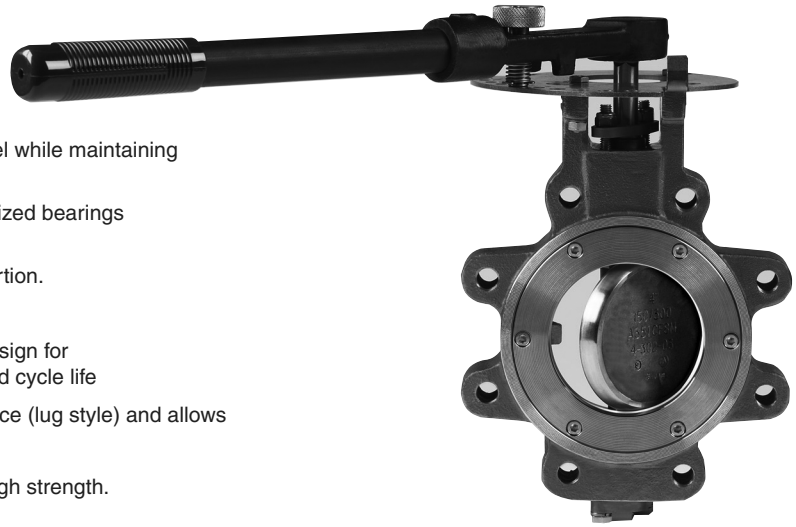

H.P. Lug Pattern

Product Range

Size Class: 2-1/2"-24", ASME/ANSI Class 150 & 300
Body Configuration: Wafer and Lug

Operators Available

10 Position Lever Handle, Gear Operators, Pneumatic and Electric Actuators

Material of Standard Construction

Body Carbon Steel or CF8M 316 Stainless Steel
Disc CF8M 316 Stainless Steel
Stem 17-4 PH Stainless Steel
Bearing Stainless backed RTFE
Seat RTFE/Stainless Garter Spring

Specifications

Valve Sizes 2-1/2" through 24"
Flanged Ends Connections per ASME/ANSI B16.5.

Valve face to face dimension per MSS-SP-68.

Valve bodies are cast high quality steel, with standard availability in ASTM-A216 WCB CS and ASTM A-351 CF8M SS. Body wall thickness meets ASME/ANSI B16.34 and complies with quality standard for steel castings MSS-SP-55.

High performance valve meets the requirements of MSS-SP-68 for double offset design.

Valve pressure tests meet MSS-SP-61.

Valve testing and inspection meet API 598.

Tagging meets the requirements of MSS-SP-25 and API 609B.

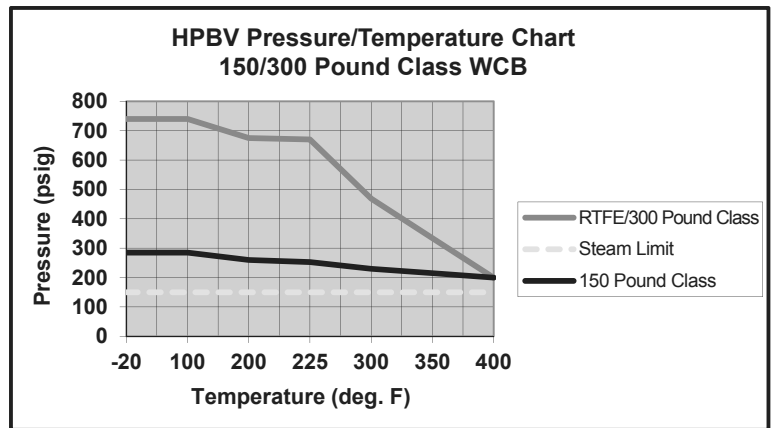

Pressure Ratings*
(Cold Working Pressure)

	2-1/2" through 24" Class 150	2-1/2" through 16" Class 300
Carbon Steel	285 psi	740 psi
Stainless Steel	275 psi	720 psi

*Valve is rated @ 150 PSI steam for on & off application and 50 PSI modulating service. (Limit Range 30°-70° - No Dwell In Near Closed Position.)

HOW TO ORDER MILWAUKEE VALVES HP SERIES HIGH PERFORMANCE BUTTERFLY VALVE											
SERIES	ANSI CLASS	BODY STYLE	BODY MATERIAL	DISC MATERIAL	STEM MATERIAL	SEAT MATERIAL	STEM PACKING	OPERATOR	EXT. OPTIONS	SIZE	
XX	X	X	X	X	X	X	X	X	XX	XXX	
HP	1-150 3-300	L-LUG W-WAFER	C-WCB S-CF8M	S-CF8M	4-17-4 SS 5-316 SS	1-PTFE 2-RPTFE 4-UHMWPE	1-PTFE G-GRAPHITE	1-BARE STEM 2-LEVER-LOCK 3-GEAR OP 4-ELECTRIC 5-PNEUMATIC 6-Epoxy Ctd. Gear Op 7-Epoxy Ctd. Lever-Lock	A-Assemble Dry C-Chlorine Clean E-Extended Mounting L-Locking O-Oxygen Clean (Consult Factory) S-Stainless Steel Seat Retainer U-Assembled in USA	025-240	
PART NUMBER EXAMPLE											
HP1LC4111 040 = 4 INCH, HIGH PERFORMANCE, CLASS 150, LUG PATTERN, CARBON STEEL BODY, 17-4 STEM, PTFE SEAT, PTFE PACKING, BARE STEM WITH NO EXT OPTIONS											

The information presented on this sheet is correct at the time of publication. Milwaukee Valve reserves the right to change design, and/or material specifications without notice. For the Installation, Operation and Maintenance Manual (IOM) see the Technical/Service Information section on our website. For the most current information access www.milwaukeevalve.com

Rev. 4



HP Series Lug 2 1/2" - 8" with Lever

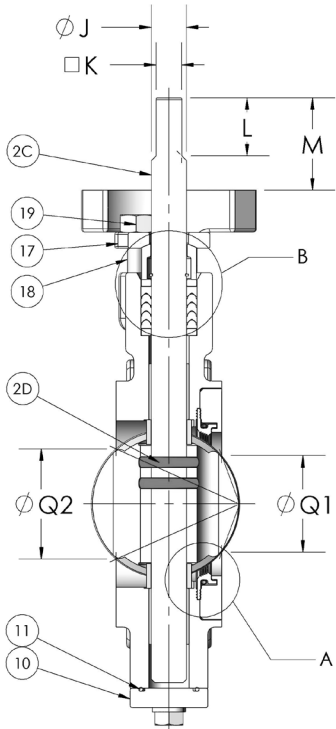

VALVE SHOWN OPEN

2-1/2" - 6" 150/300 LB & 8" 150 LB LUG WITH HANDLE			
ITEM NO.	PARTS NAME	MATERIAL	SPECIFICATION
1	BODY	A. CARBON STEEL	ASTM A216 GR. WCB
		B. STAINLESS STEEL	ASTM A351 GR. CF8M
2	STEM & DISC ASSEMBLY		
	2B. DISC	STAINLESS STEEL	ASTM A351 GR. CF8M
	2C. STEM	STAINLESS STEEL	17-4PH H1150
	2D. TAPER PIN	18-8 STAINLESS STEEL	COMMERCIAL
3	STEM RETAINER	304 STAINLESS STEEL	COMMERCIAL
4	SEAT RETAINER RING	A. CARBON STEEL	ASTM A515 GR. 70
		B. STAINLESS STEEL	ASTM A240 TY.316
5	SOCKET HEAD CAP SCREW	STAINLESS STEEL	ASTM A193 GR. B8M
6	SEAT	A. PTFE COMMERCIAL	COMMERCIAL
		B. 15% GLS. FLD. PTFE	COMMERCIAL
		C. UHMWPE	COMMERCIAL
7	SEAT SPRING	STAINLESS STEEL	COMMERCIAL
8	DISC SPACER	316 STAINLESS STEEL	COMMERCIAL
9	BEARING	STAINLESS STEEL - PTFE COATED	COMMERCIAL
10	BOTTOM CAP	STAINLESS STEEL	ASTM A351 GR. CF8M
11	BOTTOM SEAL	GRAPHITE	COMMERCIAL
12	HEX HEAD CAP SCREW	STAINLESS STEEL	ASTM A193, GR. B8M
13	SPLIT LOCKWASHER	STAINLESS STEEL	COMMERCIAL
14	PACKING V-RING SET	A. PTFE COMMERCIAL	COMMERCIAL
		B. GRAPHITE	COMMERCIAL
15	PACKING WASHER	304 STAINLESS STEEL	COMMERCIAL
16	GLAND FOLLOWER	STAINLESS STEEL	ASTM A351 GR. CF8M
17	GLAND RETAINER	STAINLESS STEEL	ASTM A351 GR. CF8M
18	STUD	STAINLESS STEEL	ASTM A193 GR. B8M
19	HEAVY HEX NUT	STAINLESS STEEL	ASTM A194 GR. 8M
20	SOCKET HEAD CAP SCREW	STAINLESS STEEL	ASTM A193 GR. B8M
21	SPLIT LOCKWASHER	STAINLESS STEEL	COMMERCIAL
22	HANDLE ASSY	DUCTILE IRON	COMMERCIAL

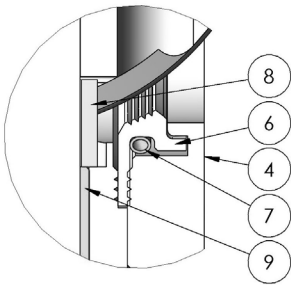

DETAIL A

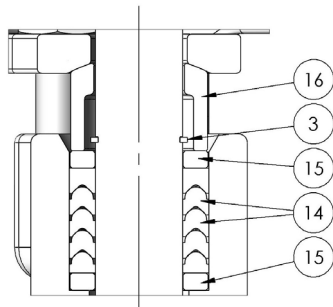

DETAIL B

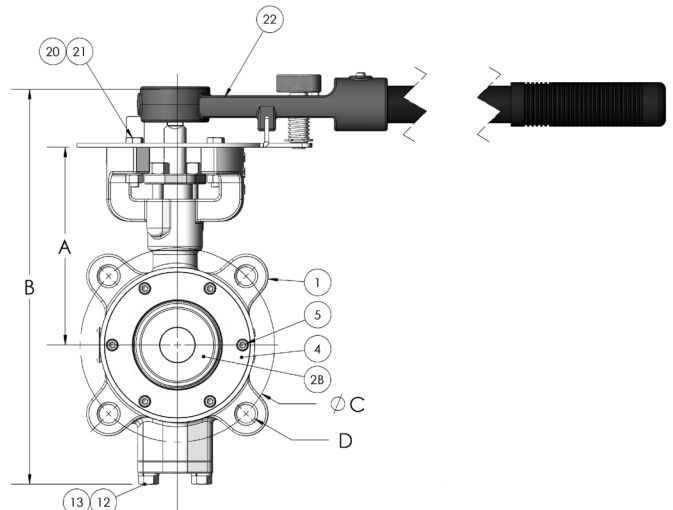
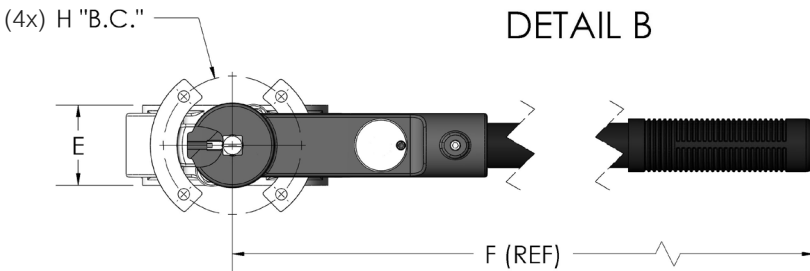

2.5" CLASS 150 HP LUG SHOWN

2.5" - 6" 150/300LB & 8" 150LB LUG WITH HANDLE																	
VALVE SIZE	VALVE DIMENSIONS					TOP WORKS				STEM CONNECTION					CORE DIMS		Bolt Ø
	"A" HEIGHT	"B" HEIGHT	"C" B.C.	"D" TAP	# OF HOLES	"E" FACE	"F"	"H" B.C.	"J" ØSTEM	"K" SQUARE	"L" LENGTH	"L2"	"M" LENGTH	"N" KEYWAY	ØQ1	ØQ2	
2.5" 150 LUG	5.59	11.24	5.50	5/8-11	4	1.88	16.87	3.25	0.62	0.46	1.02	N/A	1.64	N/A	1.72	1.97	0.27
2.5" 300 LUG	5.59	12.01	5.88	3/4-10	8	1.88	16.87	3.25	0.62	0.46	1.02	N/A	1.64	N/A	1.72	1.97	0.27
3" 150 LUG	5.59	11.24	6.00	5/8-11	4	1.88	16.87	3.25	0.62	0.46	1.02	N/A	1.72	N/A	2.28	2.47	0.27
3" 300 LUG	5.59	11.97	6.63	3/4-10	8	1.88	16.87	3.25	0.62	0.46	1.02	N/A	1.72	N/A	2.28	2.47	0.27
4" 150 LUG	6.25	12.77	7.50	5/8-11	8	2.13	16.87	3.25	0.62	0.46	1.02	N/A	1.56	N/A	3.06	3.53	0.27
4" 300 LUG	6.25	13.05	7.88	3/4-10	8	2.13	16.87	3.25	0.62	0.46	1.02	N/A	1.56	N/A	3.06	3.53	0.27
5" 150 LUG	7.69	15.52	8.50	3/4-10	8	2.13	19.87	4.25	0.87	0.64	1.04	N/A	1.69	N/A	4.35	4.46	0.44
5" 300 LUG	7.69	15.52	9.25	3/4-10	8	2.13	19.87	4.25	0.87	0.64	1.04	N/A	1.69	N/A	4.35	4.46	0.44
6" 150 LUG	7.69	15.52	9.50	3/4-10	8	2.25	19.87	4.25	0.87	0.64	1.04	N/A	1.69	N/A	5.33	5.43	0.44
6" 300 LUG	7.69	16.56	10.63	3/4-10	12	2.31	19.87	4.25	0.87	0.64	1.04	N/A	1.69	N/A	5.33	5.39	0.44
8" 150 LUG	9.51	19.27	13.00	3/4-10	8	2.63	22.85	4.75	1.12	N/A	N/A	1.50	1.86	0.25	7.10	7.37	0.56

Rev. 2

The information presented on this sheet is correct at the time of publication. Milwaukee Valve reserves the right to change design, and/or material specifications without notice. For the Installation, Operation and Maintenance Manual (IOM) see the Technical/Service Information section on our website. For the most current information access www.milwaukeevalve.com



HP Series Lug 2 1/2" - 8" with Gear

Class 150 and 300

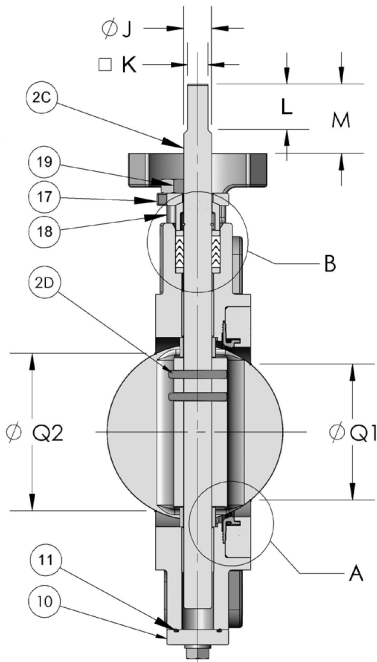

VALVE SHOWN OPEN

2-1/2" - 6" 150/300 LB & 8" 150 LB LUG WITH GEAR			
ITEM NO.	PARTS NAME	MATERIAL	SPECIFICATION
1	BODY	A. CARBON STEEL	ASTM A216 GR. WCB
		B. STAINLESS STEEL	ASTM A351 GR. CF8M
2	STEM & DISC ASSEMBLY		
	2B. DISC	STAINLESS STEEL	ASTM A351 GR. CF8M
	2C. STEM	STAINLESS STEEL	17-4PH H1150
	2D. TAPER PIN	18-8 STAINLESS STEEL	COMMERCIAL
3	STEM RETAINER	304 STAINLESS STEEL	COMMERCIAL
4	SEAT RETAINER RING	A. CARBON STEEL	ASTM A515 GR. 70
		B. STAINLESS STEEL	ASTM A240 TY.316
5	SOCKET HEAD CAP SCREW	STAINLESS STEEL	ASTM A193 GR. B8M
6	SEAT	A. PTFE COMMERCIAL	COMMERCIAL
		B. 15% GLS. FLD. PTFE	COMMERCIAL
		C. UHMWPE	COMMERCIAL
7	SEAT SPRING	STAINLESS STEEL	COMMERCIAL
8	DISC SPACER	316 STAINLESS STEEL	COMMERCIAL
9	BEARING	STAINLESS STEEL - PTFE COATED	COMMERCIAL
10	BOTTOM CAP	STAINLESS STEEL	ASTM A351 GR. CF8M
11	BOTTOM SEAL	GRAPHITE	COMMERCIAL
12	HEX HEAD CAP SCREW	STAINLESS STEEL	ASTM A193, GR. B8M
13	SPLIT LOCKWASHER	STAINLESS STEEL	COMMERCIAL
14	PACKING V-RING SET	A. PTFE COMMERCIAL	COMMERCIAL
		B. GRAPHITE	COMMERCIAL
15	PACKING WASHER	304 STAINLESS STEEL	COMMERCIAL
16	GLAND FOLLOWER	STAINLESS STEEL	ASTM A351 GR. CF8M
17	GLAND RETAINER	STAINLESS STEEL	ASTM A351 GR. CF8M
18	STUD	STAINLESS STEEL	ASTM A193 GR. B8M
19	HEAVY HEX NUT	STAINLESS STEEL	ASTM A194 GR. 8M
20	SOCKET HEAD CAP SCREW	STAINLESS STEEL	ASTM A193 GR. B8M
21	SPLIT LOCKWASHER	STAINLESS STEEL	COMMERCIAL
22	HANDLE ASSY	DUCTILE IRON	COMMERCIAL

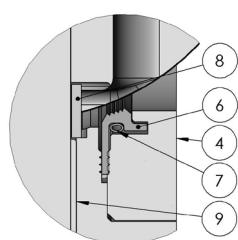

DETAIL A

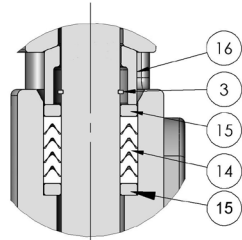

DETAIL B

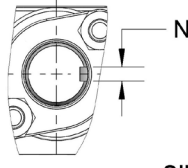

8" KEY DETAIL

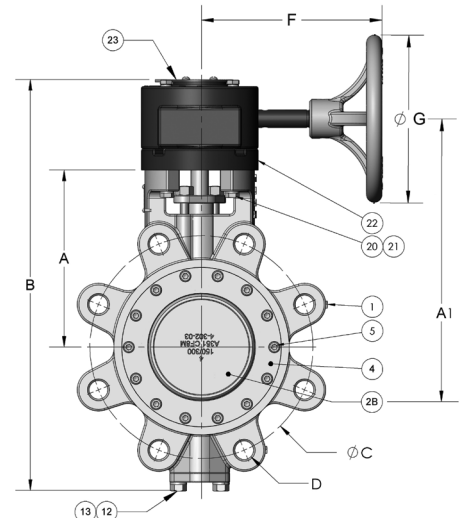
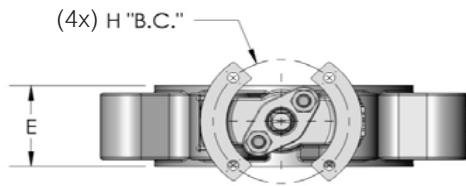

4" CLASS 300 HP LUG SHOWN

2.5" - 8" 150/300LB LUG WITH GEAR																			
VALVE SIZE	VALVE DIMENSIONS							HANDWHEEL	TOP WORKS	STEM CONNECTION							CORE DIMS		Bolt Ø
	"A" HEIGHT	"A1" HEIGHT	"B" HEIGHT	"C" B.C.	"D" TAP	# OF HOLES	"E" FACE			"F"	"G" DIA	"H" B.C.	"J" ØSTEM	"K" SQUARE	"L" LENGTH	"L2"	"M" LENGTH	"N" KEYWAY	
2.5" 150 LUG	5.59	7.40	12.72	5.50	5/8-11	4	1.88	6.37	6	3.25	0.62	0.46	1.02	N/A	1.64	N/A	1.72	1.97	0.27
2.5" 300 LUG	5.59	7.40	13.59	5.88	3/4-10	8	1.88	6.37	6	3.25	0.62	0.46	1.02	N/A	1.64	N/A	1.72	1.97	0.27
3" 150 LUG	5.59	7.40	12.72	6.00	5/8-11	4	1.88	6.37	6	3.25	0.62	0.46	1.02	N/A	1.72	N/A	2.28	2.47	0.27
3" 300 LUG	5.59	7.40	13.45	6.63	3/4-10	8	1.88	6.37	6	3.25	0.62	0.46	1.02	N/A	1.72	N/A	2.28	2.47	0.27
4" 150 LUG	6.25	8.06	14.25	7.50	5/8-11	8	2.13	6.37	6	3.25	0.62	0.46	1.02	N/A	1.56	N/A	3.06	3.53	0.27
4" 300 LUG	6.25	8.06	14.53	7.88	3/4-10	8	2.13	6.37	6	3.25	0.62	0.46	1.02	N/A	1.56	N/A	3.06	3.53	0.27
5" 150 LUG	7.69	10.30	18.70	8.50	3/4-10	8	2.13	6.02	9	4.25	0.87	0.64	1.04	N/A	1.69	N/A	4.35	4.46	0.44
5" 300 LUG	7.69	10.30	18.70	9.25	3/4-10	8	2.13	6.02	9	4.25	0.87	0.64	1.04	N/A	1.69	N/A	4.35	4.46	0.44
6" 150 LUG	7.69	10.30	18.70	9.50	3/4-10	8	2.25	6.02	9	4.25	0.87	0.64	1.04	N/A	1.69	N/A	5.33	5.43	0.44
6" 300 LUG	7.69	10.30	19.73	10.63	3/4-10	12	2.31	6.02	9	4.25	0.87	0.64	1.04	N/A	1.69	N/A	5.33	5.39	0.44
8" 150 LUG	9.51	12.01	21.67	11.75	3/4-10	8	2.63	7.93	12	4.75	1.12	N/A	N/A	1.50	1.86	0.25	7.10	7.37	0.56
8" 300 LUG	9.51	12.01	21.67	13.00	7/8-9	12	2.88	7.93	12	4.75	1.12	N/A	N/A	1.50	1.86	0.25	7.10	7.20	0.56

The information presented on this sheet is correct at the time of publication. Milwaukee Valve reserves the right to change design, and/or material specifications without notice. For the Installation, Operation and Maintenance Manual (IOM) see the Technical/Service Information section on our website. For the most current information access www.milwaukeevalve.com

Rev. 3



HP Series Lug 10"- 24" with Gear

Class 150 and 300

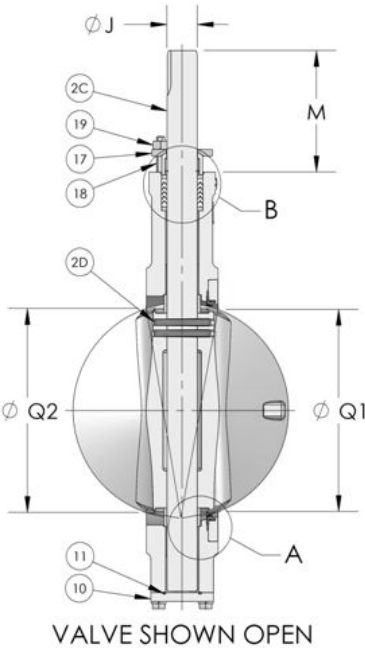

10" - 16" 150 & 300 18" - 24" 150 LUG WGEAR			
ITEM NO.	PARTS NAME	MATERIAL	SPECIFICATION
1	BODY	A. CARBON STEEL	ASTM A216 GR. WCB
		B. STAINLESS STEEL	ASTMA351 GR. CF8M
2	STEM & DISC ASSEMBLY		
	2B. DISC	STAINLESS STEEL	ASTM A351 GR. CF8M
	2C. STEM	STAINLESS STEEL	17-4PH H1150
	2D. TAPER PIN	18-8 STAINLESS STEEL	COMMERCIAL
3	STEM RETAINER	304 STAINLESS STEEL	COMMERCIAL
4	SEAT RETAINER RING	A. CARBON STEEL	ASTM A515 GR. 70
		B. STAINLESS STEEL	ASTM A240 TY.316
5	SOCKET HEAD CAP SCREW	STAINLESS STEEL	ASTM A193 GR. B8M
6	SEAT	A. PTFE COMMERCIAL	COMMERCIAL
		B. 15% GLS. FLD. PTFE	COMMERCIAL
		C. UHMWPE	COMMERCIAL
7	SEAT SPRING	STAINLESS STEEL	COMMERCIAL
8	DISC SPACER	316 STAINLESS STEEL	COMMERCIAL
9	BEARING	STAINLESS STEEL - PTFE COATED	COMMERCIAL
10	BOTTOM CAP	STAINLESS STEEL	ASTM A351 GR. CF8M
11	BOTTOM SEAL	GRAPHITE	COMMERCIAL
12	HEX HEAD CAP SCREW	STAINLESS STEEL	ASTM A193, GR. B8M
13	SPLIT LOCKWASHER	STAINLESS STEEL	COMMERCIAL
14	PACKING V-RING SET	A. PTFE COMMERCIAL	COMMERCIAL
		B. GRAPHITE	COMMERCIAL
15	PACKING WASHER	304 STAINLESS STEEL	COMMERCIAL
16	GLAND FOLLOWER	STAINLESS STEEL	ASTM A351 GR. CF8M
17	GLAND RETAINER	STAINLESS STEEL	ASTM A351 GR. CF8M
18	STUD	STAINLESS STEEL	ASTM A193 GR. B8M
19	HEAVY HEX NUT	STAINLESS STEEL	ASTM A194 GR. 8M
20	MOUNTING PLATE	STAINLESS STEEL	COMMERCIAL
21	HEX HEAD CAP SCREW	STAINLESS STEEL	ASTM A193, GR. B8M
22	SPLIT LOCKWASHER	STAINLESS STEEL	COMMERCIAL
23	HEX HEAD CAP SCREW	STAINLESS STEEL	ASTM A193, GR. B8M
24	SPLIT LOCKWASHER	STAINLESS STEEL	COMMERCIAL
25	GEAR OPERATOR	-	-

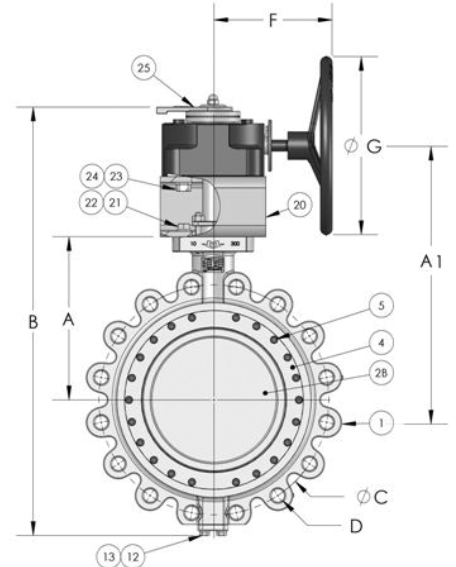
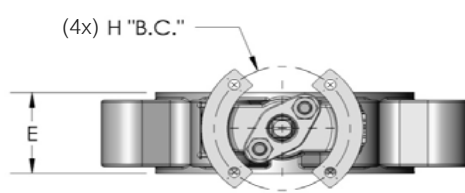
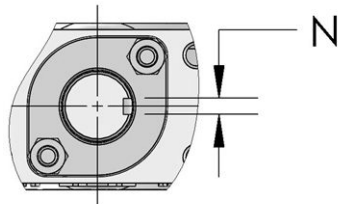
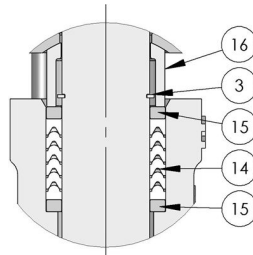
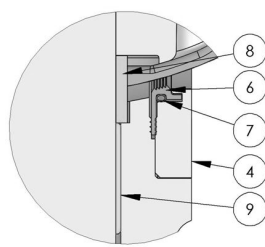
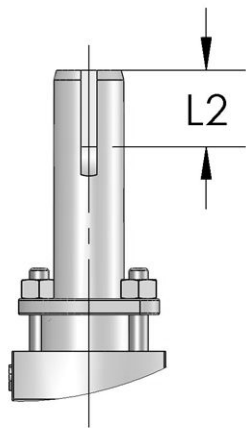

10" - 16" 150 & 300 18" - 24" 150 LUG WGEAR																	
VALVE SIZE	VALVE DIMENSIONS						HANDWHEEL		TOP WORKS		STEM CONNECTION				CORE DIMS		Bolt ϕ
	"A" HEIGHT	"A1" HEIGHT	"B" HEIGHT	"C" B.C.	"D" TAP	# OF HOLES	"E" FACE	"F"	"G" DIA	"H" B.C.	"J" ϕ STEM	"L2" LENGTH	"M" LENGTH	"N"	ϕ Q1	ϕ Q2	
10"- 150 LUG	10.54	13.04	23.15	14.25	7/8-9	12	2.81	7.93	12	4.75	1.12	1.50	1.81	0.25	9.30	9.38	0.56
10"- 300 LUG	10.81	16.86	28.40	15.25	1-1/8-8	16	3.25	7.85	12	4.37	1.37	1.50	5.51	0.31	9.16	9.25	1/2" - 13"
12"- 150 LUG	11.62	17.67	30.40	17.00	7/8-9	12	3.19	7.85	12	4.37	1.37	1.50	5.51	0.31	10.36	10.48	1/2" - 13"
12"- 300 LUG	11.62	17.98	31.18	17.75	1-1/8-8	16	3.63	8.63	12	4.92	1.50	1.50	5.88	0.38	10.25	10.34	1/2" - 13"
14"- 150 LUG	12.00	18.36	31.74	18.75	1-1/8-8	12	3.63	8.36	12	4.92	1.50	1.50	5.50	0.38	11.69	11.76	1/2" - 13"
14"- 300 LUG	13.50	19.61	35.12	20.25	1-1/8-8	20	4.63	10.96	20	6.27	2.00	2.38	6.02	0.50	11.39	11.49	1/2" - 13"
16"- 150 LUG	14.00	20.11	35.96	21.25	1-1/8-8	16	4.00	10.96	20	6.27	2.00	2.38	6.02	0.50	13.65	13.72	1/2" - 13"
16"- 300 LUG	15.00	21.09	38.12	22.50	1-1/4-8	20	5.25	11.95	20	6.27	2.25	2.38	6.02	0.50	13.26	13.36	1/2" - 13"
18"- 150 LUG	15.00	21.09	38.12	22.75	1-1/8-8	16	4.47	11.95	20	6.27	2.25	2.38	6.02	0.50	15.65	15.72	1/2" - 13"
20"- 150 LUG	17.00	24.19	40.03	25.00	1-1/8-8	20	5.00	16.54	16	6.27	2.50	2.38	6.48	0.63	17.57	17.64	1/2" - 13"
24"- 150 LUG	19.50	25.69	49.30	29.50	1-1/4-8	20	6.06	16.54	16	7.21	3.00	2.50	6.52	0.75	20.38	20.46	3/4" - 10"

The information presented on this sheet is correct at the time of publication. Milwaukee Valve reserves the right to change design, and/or material specifications without notice. For the Installation, Operation and Maintenance Manual (IOM) see the Technical/Service Information section on our website. For the most current information access www.milwaukeevalve.com

Rev. 3



HP Series Wafer 2 1/2" - 8" with Lever

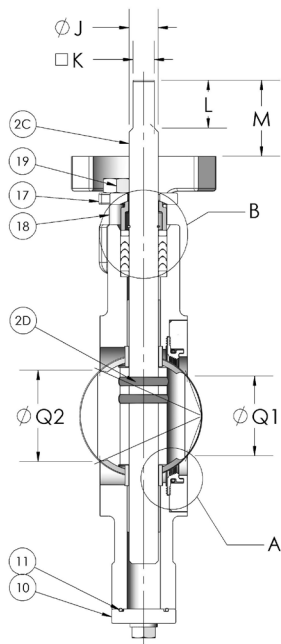

VALVE SHOWN OPEN

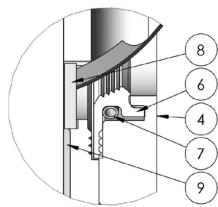

DETAIL A

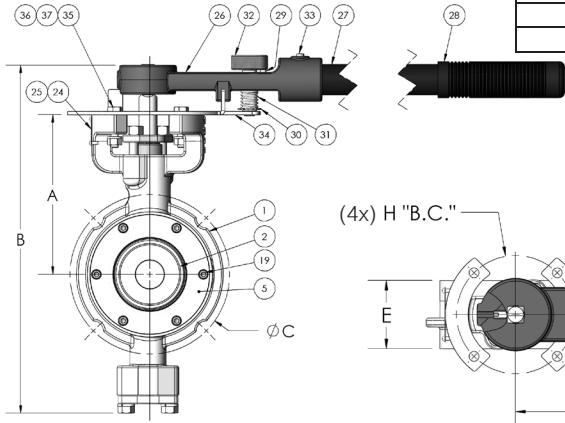

2.5" 150 / 200
WAFER SHOWN

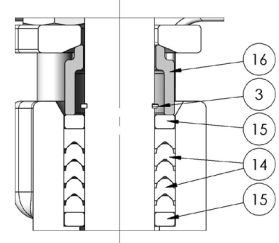
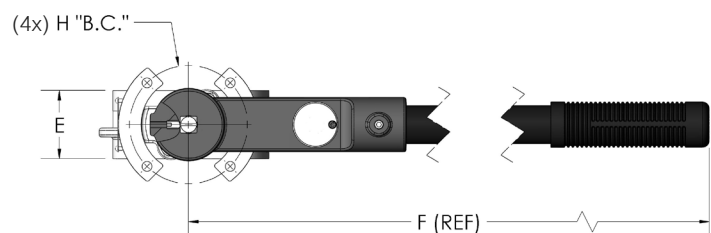

DETAIL B

2 1/2" - 8" 150/300 LB Wafer With Handle			
ITEM No.	PARTS NAME	MATERIAL	SPECIFICATION
1	150 WAFER BODY	A. CARBON STEEL	ASTM A216 GR. WCB
		B. STAINLESS STEEL	ASTM A351 GR. CF8M
2	MACHINED DISC	STAINLESS STEEL	ASTM A351 GR. CF8M
3	STEM	STAINLESS STEEL	17-4 PH COND. H1150
4	TAPER PIN	18-8 STAINLESS STEEL	COMMERCIAL
5	SEAT RETAINER RING	A. CARBON STEEL	ASTM A515 GR. 70
		B. STAINLESS STEEL	ASTM A240 TY.316
6	SEAT	A. PTFE COMMERCIAL	COMMERCIAL
		B. 15% GLASS FILLED TEFLON	COMMERCIAL
		C. UHMWPE	COMMERCIAL
7	BOTTOM CAP	STAINLESS STEEL	ASTM A351 GR. CF8M
8	STEM RETAINER	304 STAINLESS STEEL	COMMERCIAL
9	GLAND FOLLOWER	STAINLESS STEEL	ASTM A351 GR. CF8M
10	GLAND RETAINER	STAINLESS STEEL	ASTM A351 GR. CF8M
11	DISC SPACER	316 STAINLESS STEEL	COMMERCIAL
12	MALE ADAPTER	PTFE	COMMERCIAL
13	V-RING	PTFE	COMMERCIAL
14	FEMALE ADAPTER	PTFE	COMMERCIAL
15	PACKING WASHER	304 STAINLESS STEEL	COMMERCIAL
16	O-RING	VITON	COMMERCIAL
17	BEARING	STAINLESS STEEL - PTFE LINED	COMMERCIAL
18	SEAT SPRING	STAINLESS STEEL	COMMERCIAL
19	SOCKET HEAD CAP SCREW	STAINLESS STEEL	ASTM A193 GR B8M
20	WASHER, SPLIT	STAINLESS STEEL	COMMERCIAL
21	HEX HEAD CAP SCREW	STAINLESS STEEL	ASTM 193 GR. B8M
22	STUD	STAINLESS STEEL	ASTM A193 GR. B8M
23	HEAVY HEX NUT	STAINLESS STEEL	ASTM A194 GR. 8M
24	HPBV NAMEPLATE MILWAUKEE	ALUMINUM	COMMERCIAL
25	DRIVE SCREW, TY. U, #2x.25	STAINLESS STEEL, TY. 18-8	COMMERCIAL
26	4" HANDLE	DUCTILE IRON	COMMERCIAL
27	HANDLE PIPE	CARBON STEEL	COMMERCIAL
28	GRIP	VINYL	COMMERCIAL
29	ROLL PIN	STAINLESS STEEL	COMMERCIAL
30	E-CLIP	STAINLESS STEEL	COMMERCIAL
31	SPRING	STAINLESS STEEL	COMMERCIAL
32	LOCK KNOB	STAINLESS STEEL	COMMERCIAL
33	SOCKET SET SCREW	STAINLESS STEEL	COMMERCIAL
34	NOTCH PLATE	STAINLESS STEEL	COMMERCIAL
35	HEX HEAD CAP SCREW	CARBON STEEL - ZINC PLATED	COMMERCIAL
36	STD. HEX NUT	STAINLESS STEEL	COMMERCIAL
37	1/4" LOCKWASHER	STAINLESS STEEL	COMMERCIAL

2.5" - 6" 150/300LB & 8" 150LB WAFER WITH LEVER

VALVE SIZE	VALVE DIMENSIONS					TOP WORKS		STEM CONNECTION					CORE DIMS		Bolt Ø
	"A" HEIGHT	"B" HEIGHT	"C" B.C.	"E" FACE	"F"	"H" B.C.	"J" ØSTEM	"K" SQUARE	"L" LENGTH	"L2"	"M" LENGTH	"N"	ØQ1	ØQ2	
2.5" 150/300 WAFER	5.59	11.99	5.50	1.88	16.87	3.25	0.62	0.46	1.02	N/A	1.64	N/A	1.72	1.97	0.27
3" 150/300 WAFER	5.59	11.24	6.00	1.88	16.87	3.25	0.62	0.46	1.02	N/A	1.72	N/A	2.28	2.47	0.27
4" 150/300 WAFER	6.25	12.77	7.50	2.13	16.87	3.25	0.62	0.46	1.02	N/A	1.56	N/A	3.06	3.53	0.27
5" 150 WAFER	7.69	15.65	8.50	2.13	19.87	4.25	0.87	0.64	1.04	N/A	1.69	N/A	4.35	4.47	0.44
5" 300 WAFER	7.69	15.65	9.25	2.13	19.87	4.25	0.87	0.64	1.04	N/A	1.69	N/A	4.35	4.47	0.44
6" 150 WAFER	7.69	15.51	9.50	2.25	19.87	4.25	0.87	0.64	1.04	N/A	1.69	N/A	5.33	5.43	0.44
6" 300 WAFER	7.69	15.32	9.50	2.25	19.87	4.25	0.87	0.64	1.04	N/A	1.69	N/A	5.33	5.43	0.44
8" 150 WAFER	9.51	19.27	11.75	2.63	22.85	4.75	1.12	N/A	N/A	1.50	1.86	0.25	7.10	7.37	0.56

The information presented on this sheet is correct at the time of publication. Milwaukee Valve reserves the right to change design, and/or material specifications without notice. For the Installation, Operation and Maintenance Manual (IOM) see the Technical/Service Information section on our website. For the most current information access www.milwaukeevalve.com

Rev. 3

HP Series Wafer 2 1/2" - 8" with Gear

Class 150 and 300

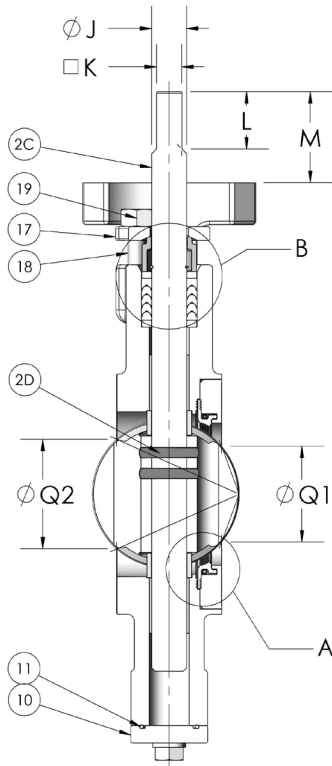

VALVE SHOWN OPEN

2-1/2" - 8" 150/300 LB WAFER WITH GEAR			
ITEM NO.	PARTS NAME	MATERIAL	SPECIFICATION
1	BODY	A. CARBON STEEL	ASTM A216 GR. WCB
		B. STAINLESS STEEL	ASTM A351 GR. CF8M
2	STEM & DISC ASSEMBLY		
	2B. DISC	STAINLESS STEEL	ASTM A351 GR. CF8M
	2C. STEM	STAINLESS STEEL	17-4PH H1150
	2D. TAPER PIN	18-8 STAINLESS STEEL	COMMERCIAL
3	STEM RETAINER	304 STAINLESS STEEL	COMMERCIAL
4	SEAT RETAINER RING	A. CARBON STEEL	ASTM A515 GR. 70
		B. STAINLESS STEEL	ASTM A240 TY.316
5	SOCKET HEAD CAP SCREW	STAINLESS STEEL	ASTM A193 GR. B8M
6	SEAT	A. PTFE COMMERCIAL	COMMERCIAL
		B. 15% GLS. FLD. PTFE	COMMERCIAL
		C. UHMWPE	COMMERCIAL
7	SEAT SPRING	STAINLESS STEEL	COMMERCIAL
8	DISC SPACER	316 STAINLESS STEEL	COMMERCIAL
9	BEARING	STAINLESS STEEL - PTFE COATED	COMMERCIAL
10	BOTTOM CAP	STAINLESS STEEL	ASTM A351 GR. CF8M
11	BOTTOM SEAL	GRAPHITE	COMMERCIAL
12	HEX HEAD CAP SCREW	STAINLESS STEEL	ASTM A193, GR. B8M
13	SPLIT LOCKWASHER	STAINLESS STEEL	COMMERCIAL
14	PACKING V-RING SET	A. PTFE COMMERCIAL	COMMERCIAL
		B. GRAPHITE	COMMERCIAL
15	PACKING WASHER	304 STAINLESS STEEL	COMMERCIAL
16	GLAND FOLLOWER	STAINLESS STEEL	ASTM A351 GR. CF8M
17	GLAND RETAINER	STAINLESS STEEL	ASTM A351 GR. CF8M
18	STUD	STAINLESS STEEL	ASTM A193 GR. B8M
19	HEAVY HEX NUT	STAINLESS STEEL	ASTM A194 GR. 8M
20	SOCKET HEAD CAP SCREW	STAINLESS STEEL	ASTM A193 GR. B8M
21	SPLIT LOCKWASHER	STAINLESS STEEL	COMMERCIAL
22	MOUNTING PLATE	STAINLESS STEEL	COMMERCIAL
23	GEAR OPERATOR	-	-

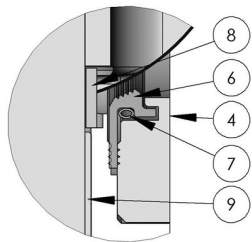

DETAIL A

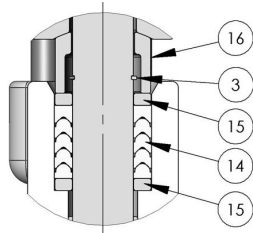

DETAIL B

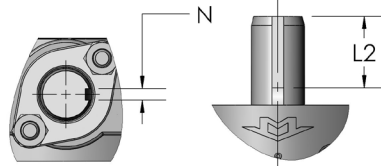

8" KEY DETAIL

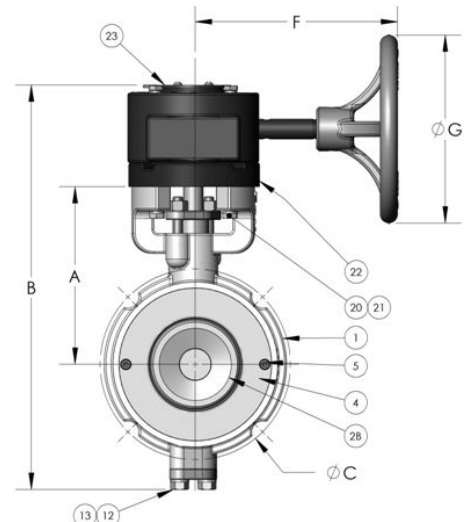
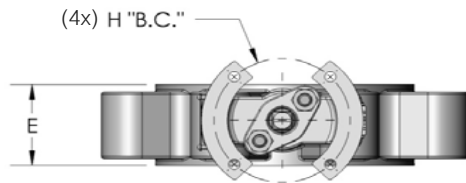

3" CLASS 150/300 HP WAFER SHOWN

2.5" - 8" 150/300LB WAFER WITH GEAR																
VALVE SIZE	VALVE DIMENSIONS					HANDWHEEL	TOP WORKS	STEM CONNECTION					CORE DIMS			Bolt ϕ
	"A" HEIGHT	"B" HEIGHT	"C" B.C.	"E" FACE	"F"			"G" DIA	"H" B.C.	"J" ϕ STEM	"K" SQUARE	"L" LENGTH	"L2"	"M" LENGTH	"N"	
2.5" 150/300 WAFER	5.59	13.57	5.50	1.88	6.37	6	3.25	0.62	0.46	1.02	N/A	1.64	N/A	1.72	1.97	0.27
3" 150/300 WAFER	5.59	12.72	6.00	1.88	6.37	6	3.25	0.62	0.46	1.02	N/A	1.72	N/A	2.28	2.47	0.27
4" 150/300 WAFER	6.25	14.25	7.50	2.13	6.37	6	3.25	0.62	0.46	1.02	N/A	1.56	N/A	3.06	3.53	0.27
5" 150 WAFER	7.69	18.83	8.50	2.13	6.02	9	4.25	0.87	0.64	1.04	N/A	1.70	N/A	4.35	4.47	0.44
5" 300 WAFER	7.69	16.94	9.25	2.13	6.52	9	4.25	0.87	0.64	1.04	N/A	1.70	N/A	4.35	4.47	0.44
6" 150 WAFER	7.69	18.69	9.50	2.25	6.02	9	4.25	0.87	0.64	1.04	N/A	1.70	N/A	5.33	5.43	0.44
6" 300 WAFER	7.69	18.50	9.50	2.25	6.02	9	4.25	0.87	0.64	1.04	N/A	1.67	N/A	5.33	5.43	0.44
8" 150 WAFER	9.51	21.67	11.75	2.63	7.93	12	4.75	1.12	N/A	N/A	1.50	1.86	0.25	7.10	7.37	0.44
8" 300 WAFER	9.51	21.67	13.00	2.88	7.93	12	4.75	1.12	N/A	N/A	1.50	1.86	0.25	7.10	7.20	0.56

The information presented on this sheet is correct at the time of publication. Milwaukee Valve reserves the right to change design, and/or material specifications without notice. For the Installation, Operation and Maintenance Manual (IOM) see the Technical/Service Information section on our website. For the most current information access www.milwaukeevalve.com

Rev. 2



HP Series Wafer 10"- 18" with Gear Class 150 and 300

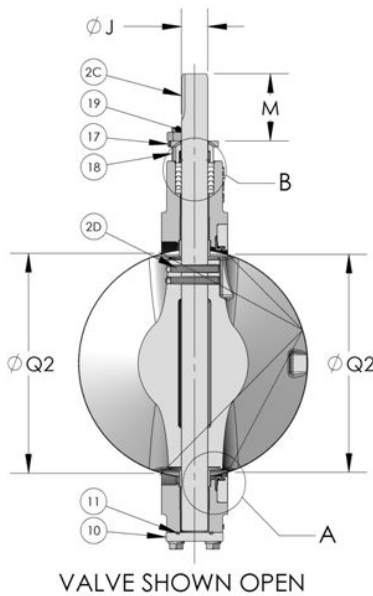

10" THRU 18" 150/300 LB WAFER WITH GEAR			
ITEM NO.	PARTS NAME	MATERIAL	SPECIFICATION
1	BODY	A. CARBON STEEL	ASTM A216 GR. WCB
		B. STAINLESS STEEL	ASTM A351 GR. CF8M
2	STEM & DISC ASSEMBLY		
	2B. DISC	STAINLESS STEEL	ASTM A351 GR. CF8M
	2C. STEM	STAINLESS STEEL	17-4PH H1150
	2D. TAPER PIN	18-8 STAINLESS STEEL	COMMERCIAL
3	STEM RETAINER	304 STAINLESS STEEL	COMMERCIAL
4	SEAT RETAINER RING	A. CARBON STEEL	ASTM A515 GR. 70
		B. STAINLESS STEEL	ASTM A240 TY.316
5	SOCKET HEAD CAP SCREW	STAINLESS STEEL	ASTM A193 GR. B8M
6	SEAT	A. PTFE COMMERCIAL	COMMERCIAL
		B. 15% GLS. FLD. PTFE	COMMERCIAL
		C. UHMWPE	COMMERCIAL
7	SEAT SPRING	STAINLESS STEEL	COMMERCIAL
8	DISC SPACER	316 STAINLESS STEEL	COMMERCIAL
9	BEARING	STAINLESS STEEL - PTFE COATED	COMMERCIAL
10	BOTTOM CAP	STAINLESS STEEL	ASTM A351 GR. CF8M
11	BOTTOM SEAL	GRAPHITE	COMMERCIAL
12	HEX HEAD CAP SCREW	STAINLESS STEEL	ASTM A193, GR. B8M
13	SPLIT LOCKWASHER	STAINLESS STEEL	COMMERCIAL
14	PACKING V-RING SET	A. PTFE COMMERCIAL	COMMERCIAL
		B. GRAPHITE	COMMERCIAL
15	PACKING WASHER	304 STAINLESS STEEL	COMMERCIAL
16	GLAND FOLLOWER	STAINLESS STEEL	ASTM A351 GR. CF8M
17	GLAND RETAINER	STAINLESS STEEL	ASTM A351 GR. CF8M
18	STUD	STAINLESS STEEL	ASTM A193 GR. B8M
19	HEAVY HEX NUT	STAINLESS STEEL	ASTM A194 GR. 8M
20	SOCKET HEAD CAP SCREW	STAINLESS STEEL	ASTM A193 GR. B8M
21	SPLIT LOCKWASHER	STAINLESS STEEL	COMMERCIAL
22	MOUNTING PLATE	STAINLESS STEEL	COMMERCIAL
23	GEAR OPERATOR	-	-

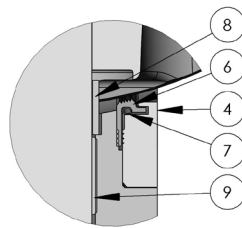
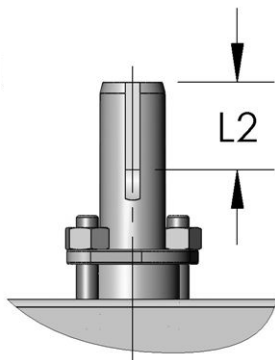

DETAIL A

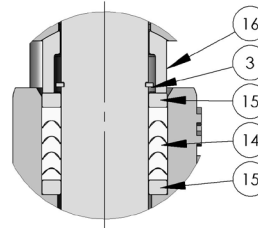

DETAIL B

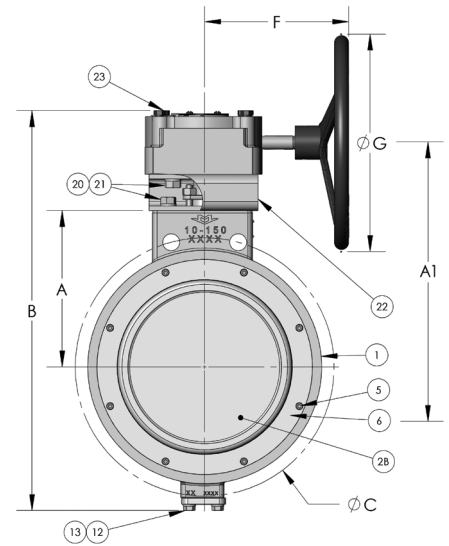

10" 150 WAFER SHOWN

10"-16" 150-300 AND 18" 150 WAFER WITH GEAR

VALVE SIZE	VALVE DIMENSIONS						HANDWHEEL	TOP WORKS	STEM CONNECTION			CORE DIMS		Bolt Ø	
	"A" HEIGHT	"A1" HEIGHT	"B" HEIGHT	"C" B.C.	"E" FACE	"F"			"H" B.C.	"J" ØSTEM	"L2"	"M" LENGTH	"N"		ØQ1
10"- 150 WAFER	8.34	14.29	22.06	14.25	2.81	7.93	12	4.11	1.12	1.50	3.72	0.25	9.30	9.38	1/2" - 13"
10"- 300 WAFER	10.81	16.86	28.40	15.25	3.25	7.85	12	4.37	1.37	1.50	5.51	0.31	9.16	9.25	1/2" - 13"
12"- 150 WAFER	11.62	17.67	29.27	17.00	3.19	7.85	12	4.37	1.37	1.50	5.51	0.31	10.36	10.48	1/2" - 13"
12"- 300 WAFER	11.59	17.64	31.18	17.75	3.63	8.36	12	4.92	1.50	1.50	5.92	0.38	10.25	10.34	1/2" - 13"
14"- 150 WAFER	12.00	18.36	31.74	18.75	3.63	8.36	12	4.92	1.50	1.50	5.50	0.38	11.68	11.76	1/2" - 13"
14"- 300 WAFER	13.50	19.61	35.12	20.25	4.63	10.96	20	6.27	2.00	2.38	6.02	0.50	11.39	11.49	1/2" - 13"
16"- 150 WAFER	14.00	20.11	35.96	21.25	4.00	10.96	20	6.27	2.00	2.38	6.02	0.50	13.65	13.72	1/2" - 13"
16"- 300 WAFER	15.00	21.09	38.12	22.50	5.25	11.95	20	6.27	2.25	2.38	6.02	0.50	13.26	13.33	1/2" - 13"
18"- 150 WAFER	15.00	21.09	37.74	22.75	4.50	11.95	20	6.27	2.25	2.38	6.02	0.50	15.63	15.71	1/2" - 13"

The information presented on this sheet is correct at the time of publication. Milwaukee Valve reserves the right to change design, and/or material specifications without notice. For the Installation, Operation and Maintenance Manual (IOM) see the Technical/Service Information section on our website. For the most current information access www.milwaukeevalve.com

Rev. 3

