



Model 3700 Ball Valve

- Epoxy Coated A126 Class B Cast Iron Body.
- Teflon-fused Solid Ball.
- Same end-to-end as any flanged gate valve.
- Tapped & plugged boss allows for venting or draining downstream.
- 2" through 8" - Full Port.
- Rated 200W @200°F.
- Class VI Positive Shutoff.
- 100% Lead-Free
- Low Torque.
- Ideal for Liquid, Air, and Backflow applications.

Materials

| Part | Material |
|---------------------|------------------------|
| Body | Cast Iron |
| Ball | Cast Iron/Teflon Fused |
| Stem | Stainless Steel |
| Gland Plate | Steel |
| Handle | Steel |
| Packing Follower | Stainless Steel |
| Fasteners | Steel/Zinc Plated |
| Packing O-Rings | EPDM |
| Body Gasket O-Rings | EPDM |
| Seat Rings | RPTFE-15% Glass Filled |
| Handle Grip | Vinyl |

AMERICAN VALVE' S PATENTED TEFLON- FUSED BALL

Model 3700 features the patented fusion process developed by American Valve over 10 years ago.

This feature eliminates ball pitting, prevents build-up, lowers torque, and stops premature valve failure.

Since the Teflon is actually impregnated .008" into the metal, it can't wear, chip, or flake.

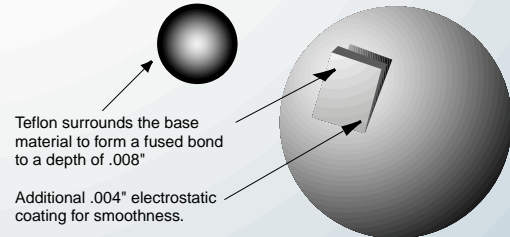

Teflon surrounds the base material to form a fused bond to a depth of .008"

Additional .004" electrostatic coating for smoothness.

Together they produce the strength of steel with the corrosion resistance of Teflon. Our patented process has gained the best of both worlds...Strength, Lubricity, and Bonding.

*Teflon is a registered trademark of DuPont

Dimensions - Weights

| | 2" | 2 1/2" | 3" | 4" | 6" | 8" |
|---------------------------------|-------|--------|--------|--------|--------|--------|
| A Face to Face | 7 | 7 1/2 | 8 | 9 | 10 1/2 | 11 1/2 |
| B Center or Port to Top | 5 1/2 | 6 | 6 3/8 | 7 1/8 | 8 7/8 | 10 3/8 |
| C Flange Diameter | 6 | 7 | 7 1/2 | 9 | 11 | 13 1/2 |
| D Center of Valve to Handle End | 12 | 10 1/8 | 10 7/8 | 12 5/8 | 16 3/4 | 19 3/4 |
| Port Diameter | 2 | 2 1/2 | 3 | 4 | 6 | 8 |
| Bolt Holes | 4 | 4 | 4 | 8 | 8 | 8 |
| Weight (lbs.) | 22 | 27 | 35 | 56 | 113 | 194 |

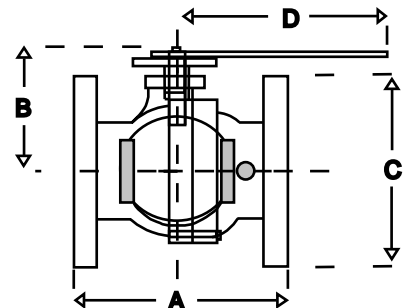

P.O. Box 35229
Greensboro, NC 27425
Toll-Free 1-800-645-0101
Fax 1-800-876-0109

www.americanvalve.com
sales@americanvalve.com

