

Steam Traps

High-Pressure Thermodynamic Steam Trap

TD3600

Thermodynamic

Model	TD3600
Sizes	1/2", 3/4", 1"
Connections	BW, SW, 600# FLG, 1500# FLG
Body Material	Forged Alloy Steel
PMO Max. Operating Pressure	3600 PSIG
TMO Max. Operating Temperature	975 °F @ 3600 psi 1025 °F @ 2220 psi
PMA Max. Allowable Pressure	2220 PSIG @ 1025 °F 3600 PSIG @ 975 °F
TMA Max. Allowable Temperature	1025 °F @ 2220 PSIG

Note: Connections may limit Pressure & Temperature ratings.



Typical Applications

DRIP: TD3600 model steam traps are designed to handle the drainage of condensate from extremely high pressure systems, and are commonly used as drip traps on high-pressure steam mains and steam supply lines. These traps are suitable for outdoor applications that are subject to freezing as well as superheated steam conditions. The complete internal working mechanism can be completely replaced while the trap body remains in line.

How it Works

The disc is the only moving part inside a thermodynamic trap. When steam enters the trap, it creates an internal pressure above the disc that instantly forces the disc to close tightly on the seat, preventing the steam from escaping. The internal steam pressure (holding the disc and seat shut) eventually drops, and the trap re-opens. When condensate enters the trap, it pushes the disc upwards, allowing the condensate to freely discharge. If steam is present, the trap instantly shuts.

Features

- "Quick-Change" seat and disc for easy in-line repair
- High pressure applications up to 3600 PSIG
- Integral strainer to protect trap from contamination
- Hardened stainless steel seat and disc for extended service life even at extremely high pressures
- Steam trap model will operate over the entire pressure range (100-3600 PSIG)
- Suitable for superheated steam
- Freeze-proof when trap is piped in a vertical orientation for complete drainage of condensate
- Trap will function in any orientation (horizontal preferred)

Sample Specification

The steam trap shall be a thermodynamic style with body material in forged alloy steel. Available in size 1/2", 3/4" and 1" Socket Weld, Butt Weld ends or ANSI 600# & 1500# RF flanged connections. Unit shall have hardened repairable stainless steel seat and disc with a removable stainless steel sintered strainer.

Installation and Maintenance

The TD3600 can be installed in any orientation; however, with cap facing upward is preferred for longest service life. For maintenance, ALL internal components are easily removed and completely changed using a replacement kit. The TD3600 contains an integral high pressure sintered strainer for protection against dirt and scale.

Helpful Selection Information

This trap was designed for handling the drainage of condensate from EXTREMELY HIGH PRESSURE systems, with a maximum operating pressure of 3600 PSIG. The TD3600 is available in Socket Weld, Butt Weld and Flange connections from 1/2" through 1".

Options

Customized Flanged Connections:
Specify size and face-to-face dimensions.

Steam Traps

High-Pressure Thermodynamic Steam Trap

TD3600
Thermodynamic

DIMENSIONS – inches

Weight: 25 lbs.

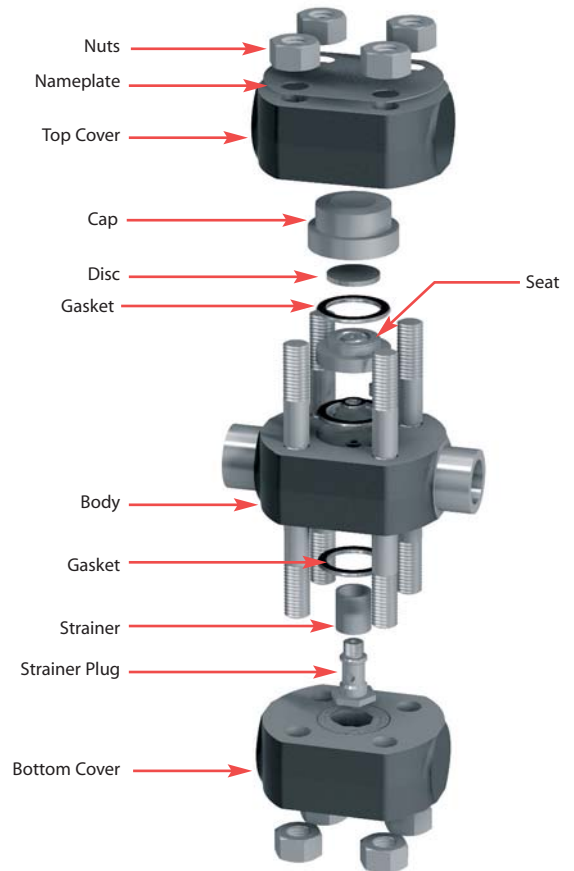
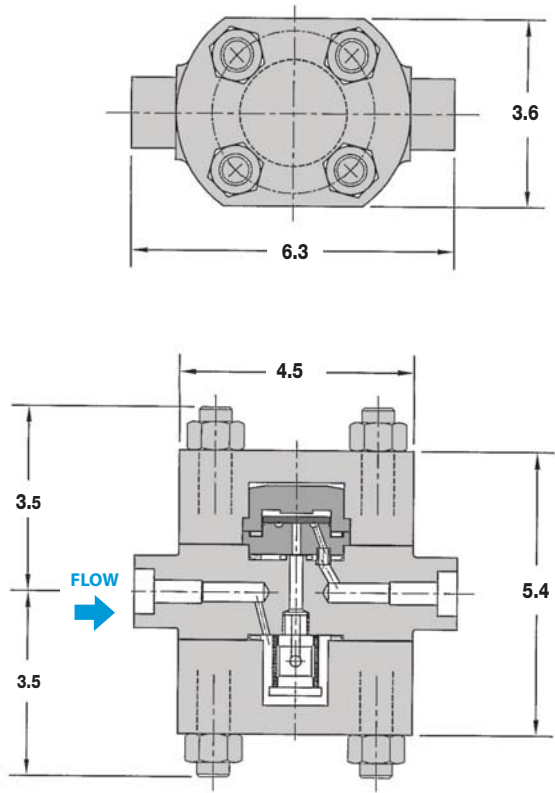

MATERIALS

Body	Forged Alloy Steel, ASTM 182 F22
Seat	Stainless Steel, AISI 420
Cover, top & bottom	Forged Alloy Steel, ASTM 182 F22
Strainer	Sintered Stainless Steel, AISI 300
Disc	Stainless Steel, AISI 420
Gasket	Stainless Steel, AISI 304
Studs	SA-193, GR B16
Nuts	SA-194, GR 4

How to Size / Order

Select working pressure; follow column down to correct capacity (lbs/hr) block. Example:

Application: 380 lbs/hr at 1000 PSIG working inlet pressure

Size/Model: **TD3600**, Specify pipe size and connections (BW, SW, 600# FLG, 1500# FLG)

CAPACITIES – Condensate (lbs/hr)

Size	Conn.	Model Code	Steam Inlet Pressure (PSIG)												
			100	500	1000	1250	1750	2000	2250	2500	2750	3000	3250	3500	3600
1/2"	SW	TD3600-12-SW													
3/4"	SW	TD3600-13-SW	165	290	380	400	435	470	500	525	550	575	595	610	625
1"	SW	TD3600-14-SW													

Note: Maximum back pressure not to exceed 50% of inlet pressure (measured in absolute pressure) or trap may not close. Add note about other connections.